

Steam Trap

스 팀 트 랫



열역학식 스팀트랩

DST-3S(Disc Type)	33
DST-1S/1F/2F(Disc Type)	34
DST-4S/4F(Disc Type)	35
BST-1S(Bypass Type)	36

기계식 스팀트랩

BKT-1S/1F(Bucket Type)	37
FLT-1S/1F/2F(Float Type)	38
PST-2F(Piston Type)	39



Steam Trap

스팀트랩은

증기시스템에서 증기가 응축하여 발생된 응축수를 효율적으로 자동배출하고 증기의 누출을 막는 자동 밸브입니다.

스팀트랩의 종류

스팀트랩은 작동원리에 의하여 세가지 형식으로 분류한다.

1. 열역학식(Thermodynamic Type)

증기와 응축수의 속도 차, 즉 운동에너지의 차이와 온도차이를 이용하여 동작한다.

- 디스크식 스팀트랩

2. 기계식(Mechanical Type)

증기와 응축수의 밀도차에 따른 부력차를 이용하여 작동되는 방식으로 생성과 동시에 연속 배출된다.

- 버킷식 스팀트랩 - 플로우트식 스팀트랩 - 피스톤식 스팀트랩

3. 온도조절식(Thermostatic Type)

증기와 응축수의 온도 차이를 이용하여 응축수를 배출하는 방식으로 응축수가 냉각되어 증기의 포화온도보다 낮은 온도에서 응축수의 현열 일부까지 이용할 수 있다.

- 씨모왁스식 스팀트랩 - 다이어프램 캡슐식 스팀트랩 - 바이메탈식 스팀트랩 - 벨로우즈식 스팀트랩

DST-3S | 디스크식 스팀트랩(Disc Type Steam Trap)

- 작동시 공기장애의 배제 및 보수가 편리하도록 제작되어 있습니다.
- 초소형 경량으로 트레이싱 라인에 적합합니다.
- 구조가 간단하고 보수가 용이합니다.
- 스트레이너가 내장되어 있어 이물질에 의한 오작동을 방지합니다.
- 디스크와 시트는 고경도 열처리 가공하였으므로 내구성이 우수합니다

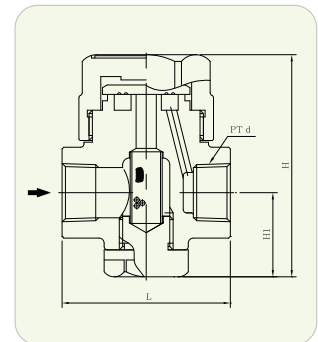

▶ 사양 (Specifications)

Working Pressure (kgf/cm ²)	Max, 20
	Min, 0.35
Design Temperature (°C)	250
Connection	Female PT Screwed
Materials	Body : Stainless Steel
	Trim : Stainless Steel

▶ 치수 (Dimensions)

Size	d	L	H1	H	Connection
8A	PT 1/4"	50	25	65	Female PT Screwed
10A	PT 3/8"	50	25	65	

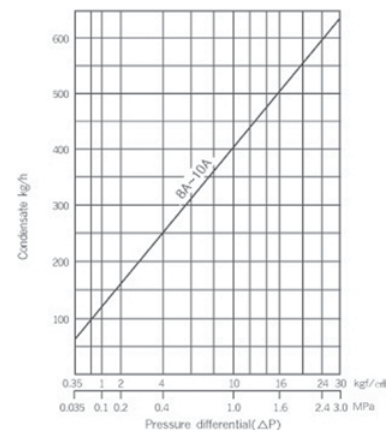

DST-1S/1F/2F | 디스크식 스팀트랩(Disc Type Steam Trap)

- 작동시 공기장애의 배제 및 보수가 편리하도록 제작되어 있습니다.
- 디스크와 시트는 스테인레스강을 사용하여 고경도 열처리 가공하여 매우 우수한 내구성을 지녔으며, 특히 시트의 구조 개선으로 몸통의 침식이 방지되며 작동도 우수합니다.
- 스트레이너가 내장되어 있어 이물질에 의한 오작동을 방지합니다.

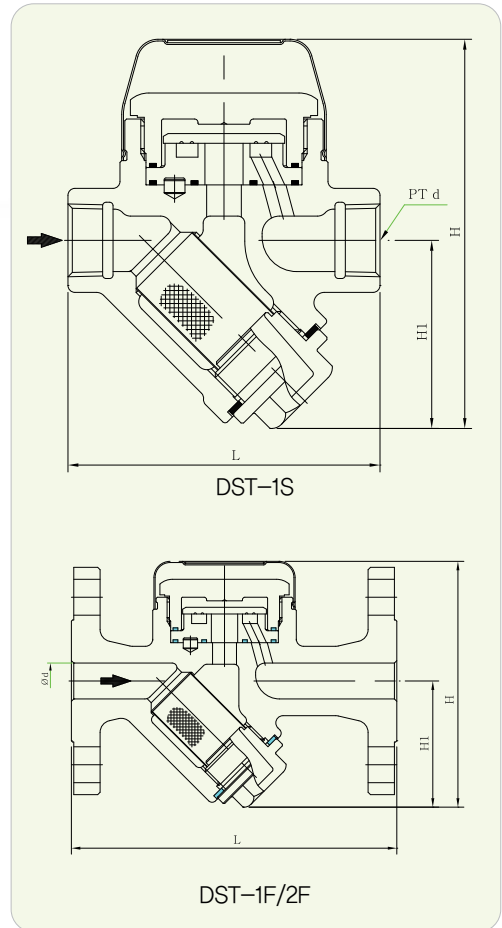

▶ 사양 (Specifications)

Model	DST-1S	DST-2F
Working Pressure (kgf/cm²)	Max. 16	Max. 20
	Min. 0.35	Min. 0.35
Design Temperature (°C)	220	250
Connection	Female PT Screwed	JIS Flanged
Materials	Body : Ductile Iron	Body : Ductile Iron, Cast Steel, Stainless Steel
	Trim : Stainless Steel	Trim : Stainless Steel

▶ 치수 (Dimensions)

Model	Size	d	L	H1	H	Connection
DST-1S	15A	PT 1/2"	90	54	104	Female PT Screwed
	20A	PT 3/4"	95	56	108	
	25A	PT 1"	100	58	112	
	32A	PT 1 1/4"	180	100	180	
	40A	PT 1 1/2"	180	110	205	
DST-1F DST-2F	15A	15	136	53	103	JIS 5K Flanged JIS 16K Flanged (DST-1F) JIS 20K Flanged (DST-2F)
	20A	20	140	55	108	
	25A	25	150	58	113	
	32A	32	190	103	185	
	40A	40	260	112	206	
	50A	50	260	112	206	

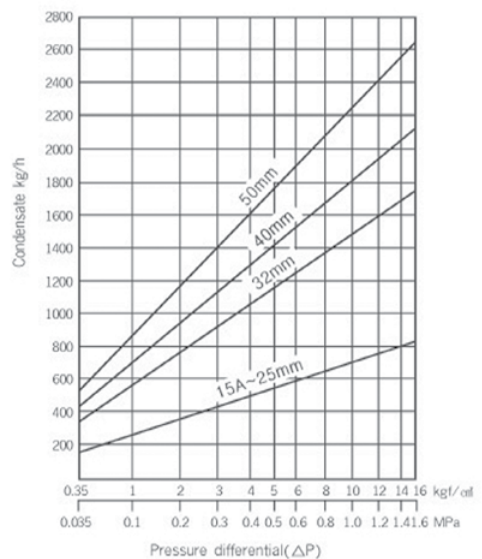

※DST-2F : ANSI, DIN 규격으로 제작할 수 있습니다.

DST-4S/4F | 디스크식 스팀트랩(Disc Type Steam Trap)

- 몸통의 재질이 스테인레스강이며, 시트 및 몸통이 일체형으로 고온 고압에 적합하게 설계되어 있습니다.
- 구조가 간단하고 보수가 용이합니다.
- 시트 및 디스크는 고경도 열처리를 하여 정밀가공 하였으므로 내구성이 우수합니다.



DST-4S



DST-4F

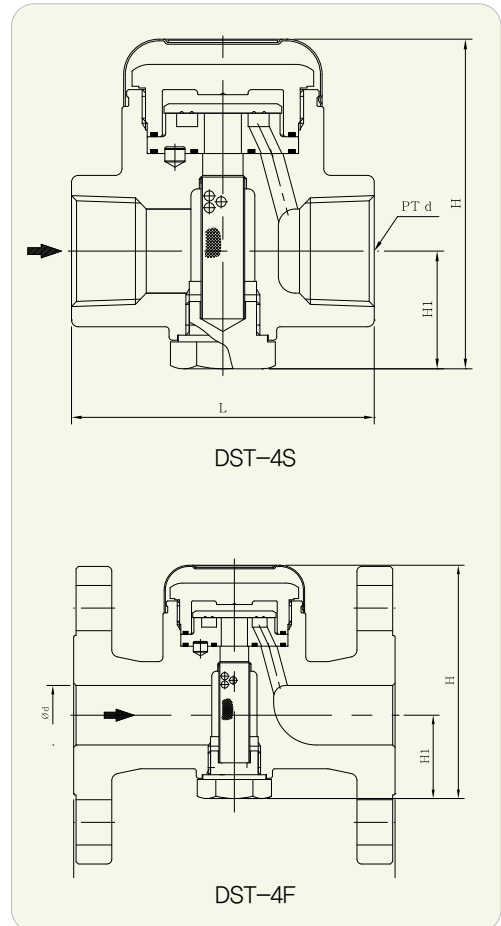

▶ 사양 (Specifications)

Working Pressure (kgf/cm ²)	Max. 20
	Min. 0.35
Design Temperature (°C)	250
Connection	DST-4S : Female PT Screwed
	DST-4F : JIS 10K, 16K, 20K Flanged
Materials	Body : Stainless Steel
	Trim : Stainless Steel

▶ 치 수 (Dimensions)

Model	Size	d	L	H1	H	Connection
DST-4S	15A	PT 1/2"	80	30	93	Female PT Screwed
	20A	PT 3/4"	80	30	93	
	25A	PT 1"	90	35	103	
DST-4F	15A	15	130	30	93	JIS 10K, 16K, 20K Flanged
	20A	20	130	30	93	
	25A	25	135	35	103	

※DST-4F : ANSI, DIN 규격으로 제작할 수 있습니다.

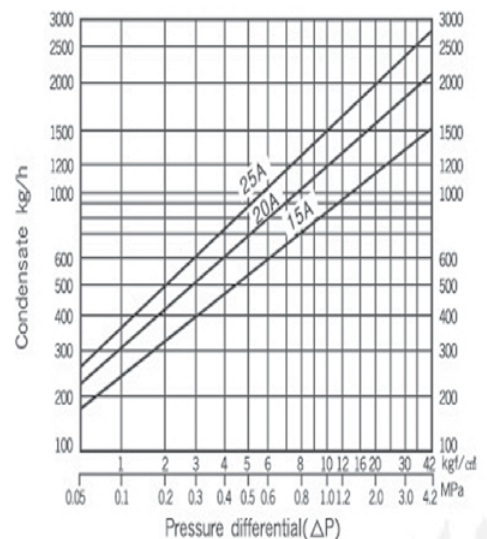

BST-1S | 바이패스 겸용 스팀트랩(By Pass Type Steam Trap)

- 바이패스 배관이 불필요함으로 설비비가 절감되고 설치면적에 구애받지 않습니다.
- 스트레이너가 내장되어 있어 이물질에 의한 오작동을 방지합니다.
- 핸들 하나만 조작하게 되면 바이패스 밸브도 되고 스팀트랩도 되는 간편한 구조의 바이패스 겸용 스팀트랩입니다.

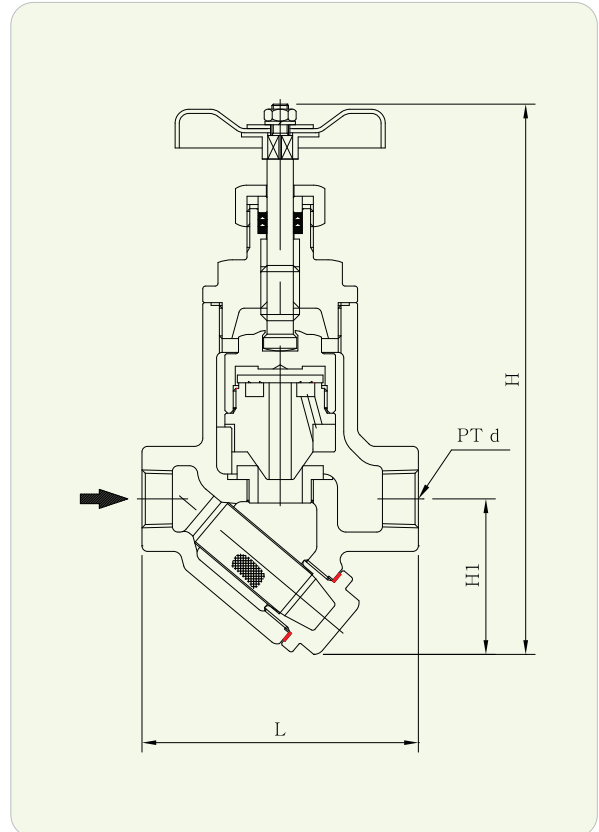

▶ 사양 (Specifications)

Working Pressure (kgf/cm ²)	Max. 16
	Min. 0.35
Design Temperature (°C)	220
Connection	Female PT Screwed
Materials	Body : Ductile Iron
	Trim : Stainless Steel

▶ 치수 (Dimensions)

Size	d	L	H1	H	Connection
15A	PT 1/2"	100	58	203	Female PT Screwed
20A	PT 3/4"	100	58	203	
25A	PT 1"	110	62	207	

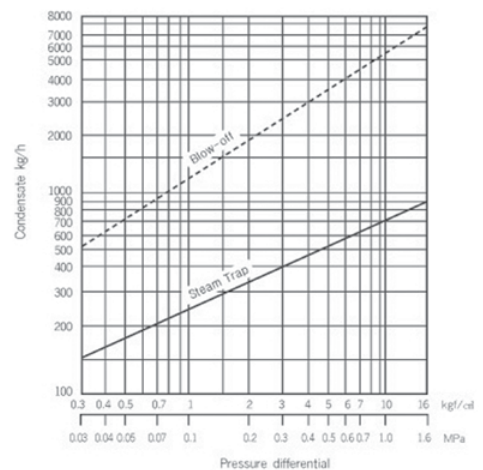

BKT-1S/1F | 버킷식 트랩(Bucket Type Steam Trap)

- 구조는 간단하고 견고하며 작동이 확실합니다.
- 버킷이 하향식으로 된 구조이기 때문에 에어 장애가 없습니다.
- 주요부의 재질이 STS이며 열처리되어 수명이 깁니다.
- 스트레이너가 내장되어 있어 이물질에 의한 오작동을 방지합니다.
- 덮개만 분리하면 손쉽게 수리할 수 있습니다.

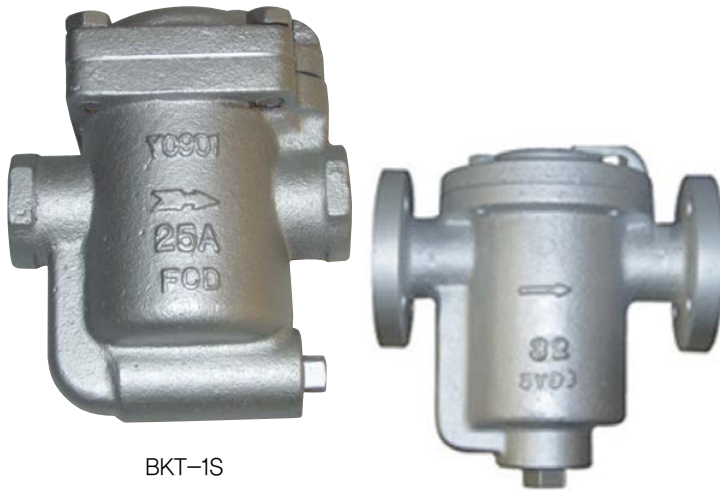

BKT-1S

BKT-1F

▶ 사양 (Specifications)

Working Pressure (kgf/cm ²)	Max. 8
	Min. 0.35
Design Temperature (°C)	220
Connection	BKT-1S : Female PT Screwed
	BKT-1F : JIS 10K Flanged
Materials	Body : Ductile Iron
	Trim : Stainless Steel

▶ 치수 (Dimensions)

Model	Size	d	L	H1	H	Connection
BKT-1S	15A	PT 1/2"	127	85	155	Female PT Screwed
	20A	PT 3/4"	127	85	155	
	25A	PT 1"	137	87	170	
	32A	PT 1 1/4"	190	185	265	
	40A	PT 1 1/2"	190	185	265	
	50A	PT 2"	240	220	305	
BKT-1F	32A	32	250	185	265	JIS 10K Flanged
	40A	40	250	185	265	
	50A	50	290	220	305	

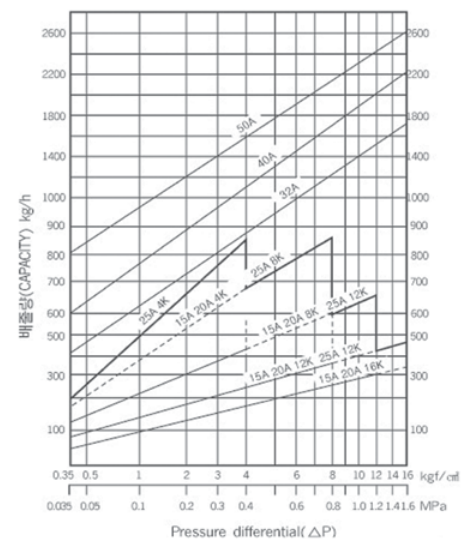
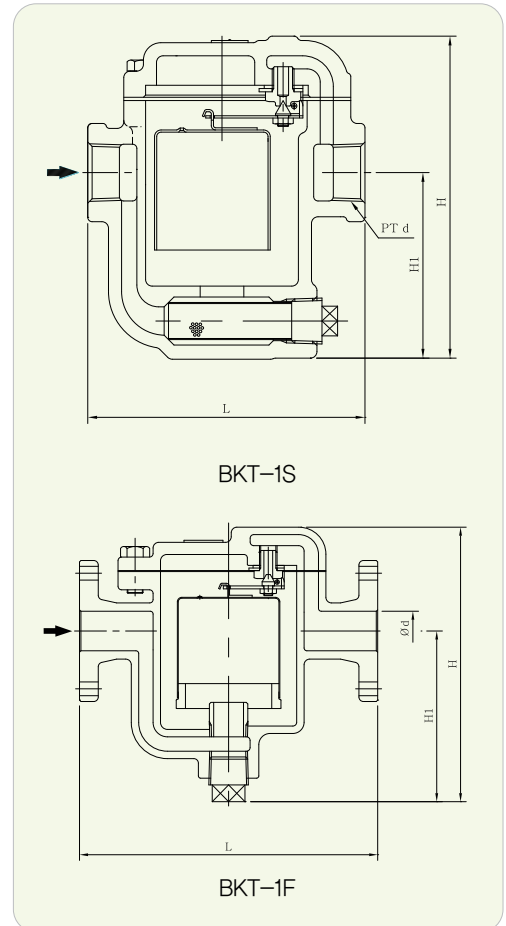

FLT-1S/1F/2F | 볼플로우트식 스팀트랩(Float Type Steam Trap)

- 공기장애를 해소시켜 주기 위해 바이메탈형 에어밴트를 내장하여 고온 고압에 적합하게 제작되었습니다.
- 부력을 이용한 기계식이므로 열교환기, 건조기, 유니트 히터 등 각종 증기설비에 널리 사용되며 고도의 정밀성을 지니 에너지 절감에 기여합니다.
- 구조가 간단하여 덮개만 분리하면 보수 및 점검을 할 수 있습니다.
- 응축수 발생량의 변화에 관계없이 안정적인 작동을 합니다.



FLT-1S



FLT-1F/2F

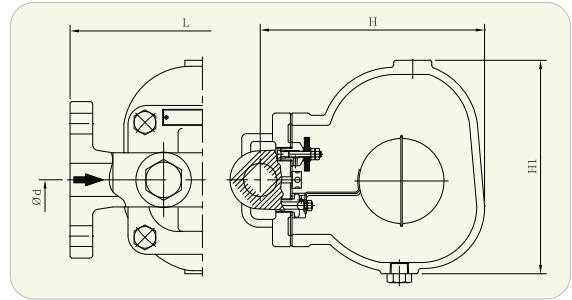
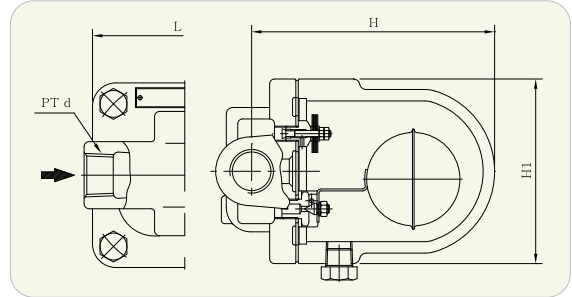

▶ 사양 (Specifications)

Model	FLT-1S	FLT-1F/2F
Working Pressure (kgf/cm ²)	Max. 16	Max. 20
	Min. 0.35	Min. 0.35
Design Temperature (°C)	220	250
Connection	Female PT Screwed	JIS 5K, 10K, 16K, 20K Flanged
Materials	Body : Ductile Iron	Body : Ductile Iron, Cast Steel, Stainless Steel
	Trim : Stainless Steel	Trim : Stainless Steel

▶ 치수 (Dimensions)

Model	Size	d	L	H1	H	Connection
FLT-1S	15A	PT 1/2"	120	110	155	Female PT Screwed
	20A	PT 3/4"	120	110	155	
	25A	PT 1"	120	185	190	
	32A	PT 1 1/4"	270	240	295	
	40A	PT 1 1/2"	270	240	295	
	50A	PT 2"	300	260	310	
FLT-1F FLT-2F	15A	15	200	110	155	JIS 5K Flanged JIS 10K Flanged JIS 16K Flanged (FLT-1F) JIS 20K Flanged (FLT-2F)
	20A	20	200	110	155	
	25A	25	215	190	185	
	32A	32	320	240	295	
	40A	40	320	240	295	
	50A	50	360	260	310	

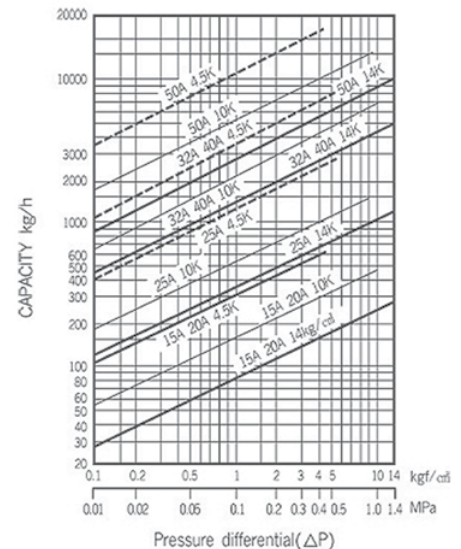

※ FLT-2F 스테인레스 재질로 제작할 수 있습니다.

※ FLT-2 주문에 따라 ANSI 플랜지로 제작할 수 있습니다.

PST-2F | 피스톤식 스팀트랩(Piston Type Steam Trap)

- 고온, 고압에 적합하게 설계되어 있습니다.
- 응축수량에 따라 민감하게 작동합니다.
- 워터해머에 관계없도록 설계되어 있으며 공기 배출이 매우 우수합니다.
- 스트레이너가 내장되어 있습니다.

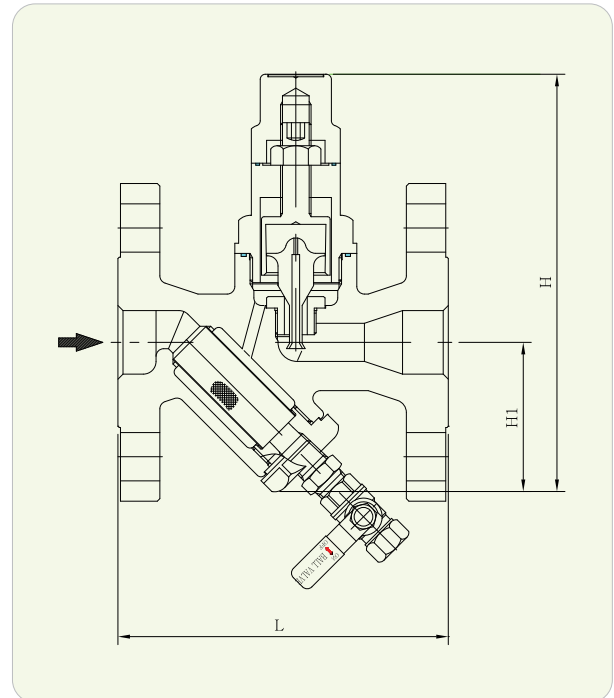

▶ 사양 (Specifications)

Working Pressure (kgf/cm ²)	Max. 20
	Min. 0.35
Design Temperature (°C)	220
Connection	JIS 10K, 16K, 20K Flanged
Materials	Body : Stainless Steel
	Trim : Stainless Steel

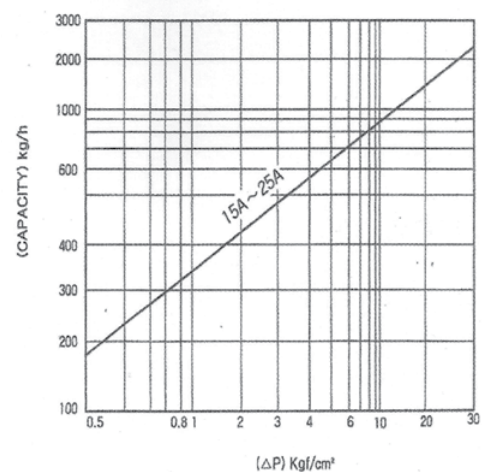

▶ 치 수 (Dimensions)

Model	Size	d	L	H1	H	Connection
PST-2F	15A	15	126	60	165	JIS 16K, 20K Flanged
	20A	20	130	60	165	
	25A	25	130	60	165	

참고자료 | 증기배관의 응축수 발생량

▶ 초기에 증기가 통과할 때 또는 보온하지 않은 배관의 응축수 발생량

A : 초기에 증기가 통과할 때 kg/min
B : 보온되지 않은 배관 kg/min

압력(kgf/cm ²)	지름(mm)	15	20	25	32	40	50	65	80	100	125	150	200	250	300
0.5 (110.7°C)	A	0.04	0.05	0.07	0.09	0.10	0.03	0.22	0.28	0.39	0.52	0.67	1.01	1.42	1.88
	B	0.08	0.10	0.13	0.16	0.18	0.23	0.29	0.33	0.42	0.52	0.61	0.80	0.99	1.17
1 (119.6°C)	A	0.04	0.05	0.07	0.10	0.11	0.15	0.25	0.30	0.43	0.58	0.74	1.11	1.57	2.07
	B	0.09	0.12	0.15	0.18	0.21	0.26	0.32	0.38	0.48	0.59	0.70	0.91	1.12	1.34
2 (132.9°C)	A	0.04	0.06	0.18	0.11	0.13	0.17	0.28	0.34	0.48	0.65	0.83	1.26	1.77	2.33
	B	0.11	0.14	0.18	0.22	0.25	0.31	0.39	0.46	0.58	0.71	0.84	1.10	1.35	1.61
3 (142.9°C)	A	0.05	0.06	0.09	0.12	0.14	0.18	0.30	0.37	0.52	0.71	0.90	1.37	1.93	1.61
	B	0.13	0.16	0.20	0.25	0.29	0.38	0.45	0.52	0.67	0.81	0.96	1.25	1.55	2.55
4 (151.1°C)	A	0.05	0.07	0.09	0.13	0.15	0.19	0.32	0.40	0.56	0.76	0.97	1.47	2.06	2.73
	B	0.14	0.18	0.22	0.28	0.32	0.39	0.50	0.58	0.74	0.90	1.07	1.40	1.72	2.05
5 (158.1°C)	A	0.05	0.07	0.10	0.13	0.16	0.20	0.34	0.42	0.59	0.80	1.02	1.55	2.18	2.88
	B	0.15	0.20	0.25	0.32	0.36	0.45	0.56	0.66	0.84	1.03	1.21	1.59	1.88	2.34
6 (164.2°C)	A	0.06	0.07	0.10	0.14	0.16	0.21	0.36	0.44	0.62	0.84	1.07	1.63	2.29	3.02
	B	0.16	0.21	0.26	0.33	0.37	0.46	0.58	0.68	0.87	1.06	1.26	1.65	2.03	2.43
7 (169.6°C)	A	0.06	0.07	0.11	0.14	0.17	0.22	0.37	0.46	0.65	0.87	1.11	1.69	2.38	3.14
	B	0.18	0.23	0.28	0.35	0.40	0.50	0.62	0.73	0.93	1.14	1.34	1.76	2.17	2.59
8 (174.5°C)	A	0.06	0.08	0.11	0.15	0.18	0.23	0.38	0.48	0.67	0.91	1.16	1.76	2.47	3.26
	B	0.19	0.24	0.30	0.37	0.42	0.53	0.66	0.77	0.99	1.21	1.28	1.87	2.31	2.76
9 (179.0°C)	A	0.06	0.08	0.12	0.15	0.18	0.24	0.40	0.49	0.70	0.94	1.20	1.82	2.56	3.39
	B	0.20	0.25	0.31	0.39	0.45	0.56	0.70	0.82	1.04	1.27	1.50	1.97	2.44	2.91
10 (183.2°C)	A	0.06	0.08	0.12	0.16	0.19	0.25	0.41	0.51	0.72	0.98	1.24	1.87	2.65	3.51
	B	0.21	0.27	0.33	0.41	0.47	0.58	0.73	0.86	1.09	1.34	1.58	2.07	2.56	3.05
15 (200.4°C)	A	0.07	0.09	0.13	0.18	0.21	0.28	0.46	0.57	0.18	1.09	1.39	2.12	2.98	3.94
	B	0.25	0.32	0.40	0.50	0.57	0.71	0.90	1.05	1.34	1.64	1.93	2.53	3.13	3.73
20 (213.9°C)	A	0.08	0.10	0.14	0.19	0.23	0.30	0.50	0.62	0.87	1.18	1.50	2.28	3.21	4.24
	B	0.29	0.26	0.46	0.57	0.65	0.81	1.02	1.19	1.53	4.87	2.21	2.89	3.57	4.26
30 (234.6°C)	A	0.00	0.12	0.174	0.23	0.27	0.35	0.59	0.73	1.03	1.39	1.77	2.69	3.78	5.00
	B	0.37	0.47	0.59	0.74	0.85	1.05	1.32	1.54	1.97	2.41	2.69	3.74	4.61	5.50

▶ 배관에 보온을 했을 때의 응축수 발생량

온도	관경(mm)	15	20	25	32	40	50	65	80	100	125	150	200	250	300
100	보온두께 mm	15	15	15	15	15	15	15	20	20	20	20	20	20	20
	응축수량 kg/min	0.05	0.06	0.07	0.08	0.08	0.10	0.11	0.12	0.14	0.17	0.19	0.23	0.27	0.31
150	보온두께 mm	15	15	20	20	20	20	25	25	25	25	25	25	30	30
	응축수량 kg/min	0.09	0.10	0.11	0.12	0.13	0.14	0.17	0.18	0.20	0.23	0.26	0.32	0.37	0.42
200	보온두께 mm	20	20	20	25	25	25	25	25	30	30	30	35	35	35
	응축수량 kg/min	0.12	0.14	0.15	0.15	0.17	0.19	0.22	0.24	0.28	0.32	0.36	0.43	0.50	0.58
250	보온두께 mm	20	25	25	25	25	30	30	30	35	35	35	40	40	40
	응축수량 kg/min	0.17	0.19	0.20	0.22	0.23	0.26	0.30	0.33	0.38	0.43	0.49	0.58	0.68	0.78
300	보온두께 mm	25	25	25	30	30	30	35	35	40	40	40	45	45	45
	응축수량 kg/min	0.22	0.25	0.28	0.30	0.33	0.37	0.42	0.46	0.53	0.60	0.68	0.80	0.94	1.08

참고자료 | 포화증기의 표

증기의 절대압력 (a b c)		증기의 온도		증발전의 물1kg의 체적	증기 1kg의 체적	증기 1m ³ 의 중량	증기 1kg이 보유한 열량 (Kcal)			증기의 절대압력 (a b c)		증기의 온도		증발전의 물1kg의 체적	증기 1kg의 체적	증기 1m ³ 의 중량	증기 1kg이 보유한 열량 (Kcal)		
							수열량	잠열	전열량								수열량	잠열	전열량
kgf/cm ²	lb/in ²	°C	°F	ℓ	m ³	kg	h	L	H=h+L	kgf/cm ²	lb/in ²	°C	°F	ℓ	m ³	kg	h	L	H=h+L
0.02	0.28	17.2	62.9	1.0012	68.26	0.147	17.2	587.8	605.0	13.5	192.0	192.4	378.3	1.1451	0.1485	6.734	195.5	469.9	665.4
0.04	0.57	28.6	83.5	1.0039	35.45	0.0288	28.7	581.3	610.0	14.0	199.1	194.1	381.4	1.1476	0.1436	6.974	197.3	468.4	665.7
0.06	0.85	35.8	96.4	1.0063	24.18	0.0414	35.8	577.3	613.1	14.5	206.2	195.8	384.4	1.1500	0.1386	7.214	199.0	466.9	665.9
0.08	1.14	41.2	106.2	1.0083	18.44	0.0542	41.2	574.2	615.4	15.0	213.3	197.4	387.3	1.1524	0.1342	7.454	200.7	465.5	666.2
0.10	1.42	45.5	113.9	1.0101	14.95	0.0669	45.4	571.8	617.2	16.0	227.4	200.4	392.7	1.1572	0.1260	7.934	204.1	462.6	666.7
0.15	2.14	53.6	128.5	1.0136	10.21	0.0980	53.5	567.1	620.6	17.0	241.7	203.4	398.1	1.1618	0.1189	8.414	207.2	459.9	667.1
0.20	2.84	59.7	139.5	1.0170	7.791	0.1284	59.6	563.5	623.1	18.0	256.0	206.2	403.2	1.1663	0.1124	8.894	210.2	457.2	667.4
0.25	3.56	64.6	148.3	1.0197	6.319	0.1583	64.5	560.8	625.2	19.0	270.2	208.8	407.8	1.1706	0.1067	9.375	213.1	454.1	667.7
0.30	4.27	68.7	155.7	1.0221	5.326	0.1878	68.7	558.2	626.9	20.0	284.4	211.4	412.5	1.1749	0.1015	9.857	215.9	452.1	668.0
0.35	4.98	72.3	162.1	1.0242	4.409	0.2170	72.2	556.1	628.3	21.0	298.6	213.9	417.0	1.1791	0.0967	10.34	218.6	450.6	668.2
0.40	5.69	75.5	167.7	1.0362	4.067	0.2459	75.4	554.2	629.6	22.0	312.8	216.2	421.2	1.1833	0.0924	10.85	221.2	447.2	668.4
0.45	6.40	78.3	172.9	1.0280	3.642	0.2746	78.3	552.5	630.8	23.0	327.1	218.5	425.3	1.1873	0.0885	11.31	223.8	448.8	668.6
0.50	7.11	80.9	177.6	1.0296	3.300	0.3030	80.3	550.9	631.8	24.0	341.3	220.8	429.4	1.1913	0.0848	11.79	226.2	442.6	668.8
0.60	8.53	85.5	185.9	1.0329	2.782	0.3594	85.5	548.1	633.6	25.0	355.5	222.9	433.2	1.1953	0.0815	12.28	228.6	440.3	668.9
0.70	9.95	89.5	193.1	1.0357	2.408	0.4152	89.5	545.7	635.2	26.0	369.7	225.0	437.0	1.1991	0.0784	12.76	230.9	438.1	669.0
0.80	11.4	93.0	199.4	1.0383	2.125	0.4705	93.0	543.5	636.5	27.0	383.9	227.0	440.6	1.203	0.0755	13.25	233.2	435.9	669.1
0.90	12.8	96.2	205.2	1.0407	1.8904	0.5253	96.2	541.5	637.5	28.0	398.2	229.0	442.2	1.207	0.0728	13.74	235.4	433.8	669.2
1.00	14.2	99.1	210.4	1.0430	1.755	0.5797	99.2	539.6	638.8	29.0	412.4	230.9	447.5	1.210	0.0703	14.23	237.5	431.7	669.2
1.20	17.1	104.3	219.7	1.0471	1.454	0.6875	104.4	536.3	640.7	30.0	426.6	232.8	451.0	1.214	0.0679	14.72	239.6	429.7	669.3
1.40	19.9	108.7	227.7	1.0580	1.259	0.7942	108.9	535.5	642.4	32.0	455.0	236.4	457.5	1.221	0.0637	15.70	243.7	425.6	669.3
1.60	22.8	112.7	234.9	1.0542	1.111	0.8999	112.9	530.8	643.7	34.0	483.5	239.8	463.6	1.229	0.0599	16.69	247.6	421.7	669.3
1.80	25.6	116.3	241.3	1.0573	0.9952	1.005	116.6	528.4	645.0	36.0	511.9	243.0	469.4	1.236	0.0565	17.69	251.3	417.9	669.2
2.00	28.4	119.6	247.3	1.0603	0.9018	1.109	119.9	526.3	646.2	38.0	540.4	246.2	475.2	1.243	0.0535	18.69	254.9	414.2	669.1
2.50	35.6	126.8	260.2	1.0669	0.7317	1.367	127.2	521.4	648.6	40.0	566.8	249.2	480.6	1.249	0.0508	19.70	258.4	410.5	669.9
3.00	42.7	132.9	271.2	1.0726	0.6168	1.621	133.4	517.2	650.6	42.0	597.2	252.1	485.8	1.256	0.0483	20.72	261.7	407.0	669.7
3.50	49.8	138.2	280.8	1.0782	0.5337	1.874	138.8	513.4	652.2	44.0	625.7	254.9	490.8	1.263	0.0460	21.74	265.0	403.5	668.5
4.00	56.9	142.9	289.2	1.0831	0.4708	2.124	143.7	510.0	653.7	46.0	654.1	257.6	495.7	1.269	0.0439	22.77	268.2	400.0	668.2
4.50	64.0	147.2	297.0	1.0877	0.4214	2.373	148.1	506.8	654.9	48.0	682.6	260.2	500.4	1.276	0.0420	23.80	271.3	396.6	667.9
5.00	71.1	151.1	304.0	1.0920	0.3816	2.620	152.1	503.9	656.0	50.0	711.0	262.7	504.9	1.283	0.0402	24.85	274.3	393.3	667.6
5.50	78.2	154.7	310.5	1.0961	0.3489	2.877	155.8	501.2	657.0	55.0	782.1	268.7	515.7	1.299	0.0364	27.49	278.5	385.1	666.6
6.00	85.3	158.1	316.6	1.1000	0.3213	3.112	159.3	498.6	657.9	60.0	853.2	274.3	525.7	1.315	0.0331	30.18	288.3	377.2	665.5
6.50	92.4	161.2	322.2	1.1037	0.2980	3.356	162.6	496.1	658.7	65.0	924.3	279.5	535.1	1.331	0.0304	32.93	294.8	369.4	664.2
7.00	99.5	164.2	327.6	1.1072	0.2778	3.660	165.7	493.8	659.5	70.0	995.4	284.5	544.1	1.347	0.0280	35.75	301.0	361.8	662.8
7.50	106.7	167.0	332.6	1.1111	0.2602	3.843	168.6	491.6	660.2	75.0	1066.5	289.2	552.6	1.363	0.0259	38.62	307.0	354.3	661.3
8.00	113.8	169.6	337.3	1.1140	0.2448	4.086	171.3	488.5	660.8	80.0	1137.6	293.6	560.5	1.379	0.0241	41.56	312.8	346.9	659.7
8.15	120.9	172.1	341.8	1.1172	0.2311	4.328	174.0	487.4	661.4	85.0	1208.7	297.9	568.2	1.395	0.0224	44.58	318.4	339.6	658.0
9.00	128.0	174.5	346.1	1.1203	0.2188	4.570	176.5	485.4	661.9	90.0	1279.5	301.9	575.4	1.421	0.0210	47.67	323.8	332.4	655.2
9.50	135.1	176.8	350.2	1.2333	0.2079	4.811	178.9	483.5	662.4	95.0	1350.9	305.8	582.4	1.429	0.0197	50.85	329.1	325.2	654.3
10.00	142.2	179.0	354.2	1.1262	0.1979	5.052	181.3	481.6	662.9	100	1422.0	309.5	589.1	1.446	0.0185	54.12	334.3	318.0	642.3
10.50	149.3	181.2	358.2	1.1291	0.1890	5.283	183.5	479.8	663.3	120	1706.4	323.1	613.6	1.518	0.0147	68.22	354.0	289.4	643.4
11.00	156.4	183.2	357.8	1.1319	0.1807	5.533	185.6	478.1	663.7	140	1990.8	335.1	633.2	1.599	0.0118	84.52	372.8	260.0	632.8
11.50	163.5	185.2	365.4	1.1346	0.1732	5.774	187.7	476.4	664.1	160	2275.2	345.8	654.4	1.693	0.0096	104.0	391.3	228.4	619.7
12.00	170.6	187.1	368.8	1.1372	0.1663	6.014	189.8	474.7	664.5	180	2559.6	355.4	671.7	1.814	0.0078	128.3	410.8	129.9	603.7
12.50	177.8	188.9	372.0	1.1400	0.1599	6.254	191.7	473.1	664.8	200	2844.0	364.1	687.4	1.990	0.0062	161.6	431.6	151.2	582.8
13.00	184.9	190.7	375.3	1.1425	0.1540	6.494	193.6	471.5	665.1	225.56	3208.7	374.15	705.47	3.170	0.0032	315.5	503.3	0	503.3

Steam Trap



Thermodynamic Type of Steam Trap

DST-3S(Disc Type)	39
DST-1S/1F/2F(Disc Type)	40
DST-4S/4F(Disc Type)	41
BST-1S(Bypass Type)	42

Mechanical Type of Steam Trap

BKT-1S/1F(Bucket Type)	43
FLT-1S/1F/2F(Float Type)	44
PST-2F(Piston Type)	45



Steam Trap

Steam traps are automatic valves that release condensed steam (condensate) from a steam space while preventing the loss of live steam. They also remove air and non-condensable from the steam space. Steam traps are design to maintain steam energy efficiency by performing specific tasks such as heating a building or maintaining heat for process.

Type of Steam Traps

1. Thermodynamic Types
2. Mechanical Type
3. Thermostatic Type

DST-3S | Disc Type Steam Trap

- Simple and Small construction.
- No trouble & low repair cost owing to integral construction of body & seat.
- Excellent durability owing to the heat-treated disc and seat.

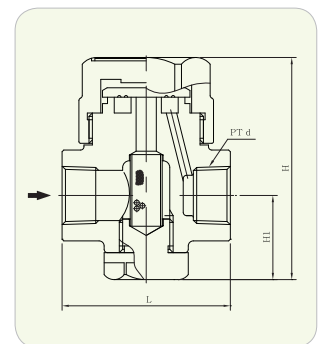

► Specifications

Working Pressure (kgf/cm ²)	Max. 20
	Min. 0.35
Working Temperature (°C)	250
Connection	PT Screwed
Materials	Body : Stainless Steel
	Trim : Stainless Steel

► Dimensions

Size	d	L	H1	H	Connection
8A	PT 1/4"	50	25	65	PT Screwed
10A	PT 3/8"	50	25	65	

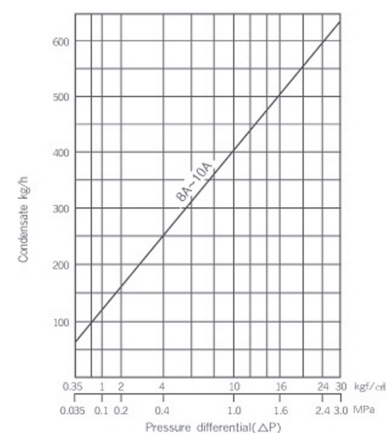

DST-1S/1F/2F | Disc Type Steam Trap

- Insulation chamber (air warm) is adopted to lessen the affect of atmosphere and to improve the most suitable working conditions.
- The maintenance and repair of disc and seat are easy owing to its material of high-hardness-treated stainless steel and its replaceable seat.

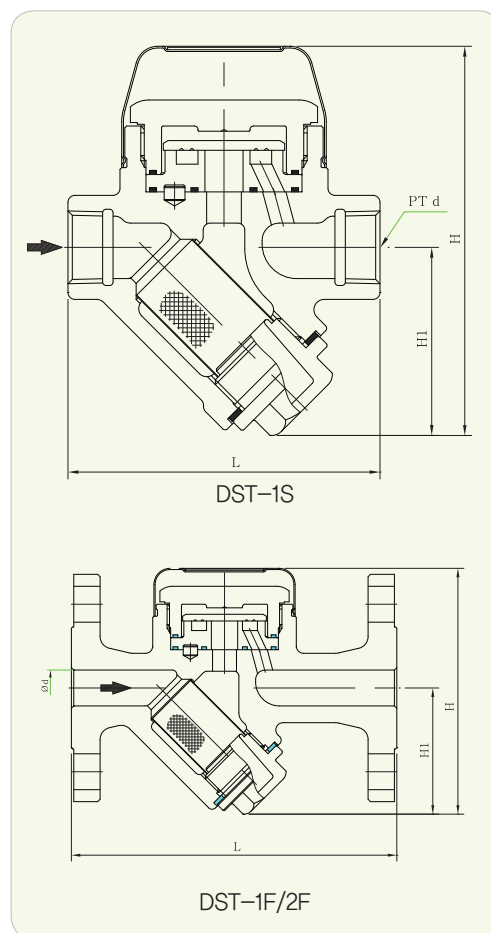

► Specifications

Working Pressure (kgf/cm ²)	Max. 16	Max. 20
	Min. 0.35	Min. 0.35
Working Temperature (°C)	220	220
Connection	DST-1S : PT Screwed	DST-2F : JIS Flanged
	DST-1F : JIS Flanged	
Materials	Body : Ductile Iron	Body : Cast Steel, Stainless Steel
	Trim : Stainless Steel	Trim : Stainless Steel

► Dimensions

Model	Size	d	L	H1	H	Connection
DST-1S	15A	PT 1/2"	90	54	104	PT Screwed
	20A	PT 3/4"	95	56	108	
	25A	PT 1"	100	58	112	
	32A	PT 1 1/4"	180	100	180	
	40A	PT 1 1/2"	180	110	205	
DST-1F DST-2F	15A	15	136	53	103	JIS 5K Flanged JIS 16K Flanged (DST-1F) JIS 20K Flanged (DST-2F)
	20A	20	140	55	108	
	25A	25	150	58	113	
	32A	32	190	103	185	
	40A	40	260	112	206	
	50A	50	260	112	206	

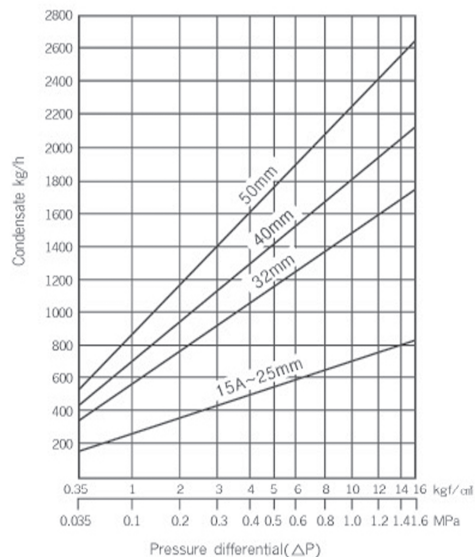

※ DST-2F – ANSI and DIN Flange are available upon request

DST-4S/4F | Disc Type Steam Trap

Steam trap is designed for high temperature – pressure steam. And for integral body with the saet.

- Small and compact design.
- Easy maintenance and replacement.
- Internal strainer built – in.
- Insulation cap adopted.



DST-4S



DST-4F

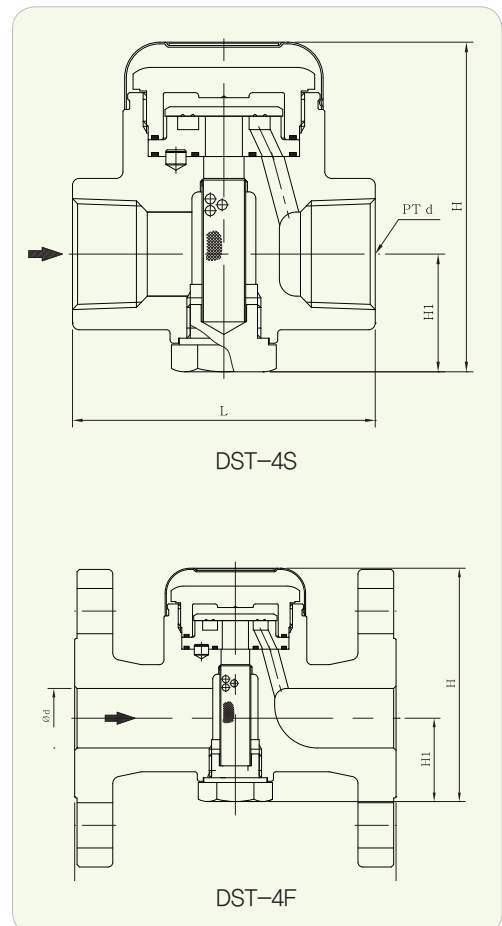

► Specifications

Working Pressure (kgf/cm ²)	Max. 20
	Min. 0.35
Working Temperature (°C)	250
Connection	DST-4S : PT Screwed
	DST-4F : JIS 10K, 20K Flanged
Materials	Body : Stainless Steel
	Trim : Stainless Steel

► Dimensions

Model	Size	d	L	H1	H	Connection
DST-4S	15A	PT 1/2"	80	34	90	PT Screwed
	20A	PT 3/4"	80	34	94	
	25A	PT 1"	90	34	97	
DST-4F	15A	15	130	35	98	JIS 10K, 20K Flanged
	20A	20	130	35	98	
	25A	25	135	35	98	

※ DST-4F – ANSI and DIN Flange are available upon request

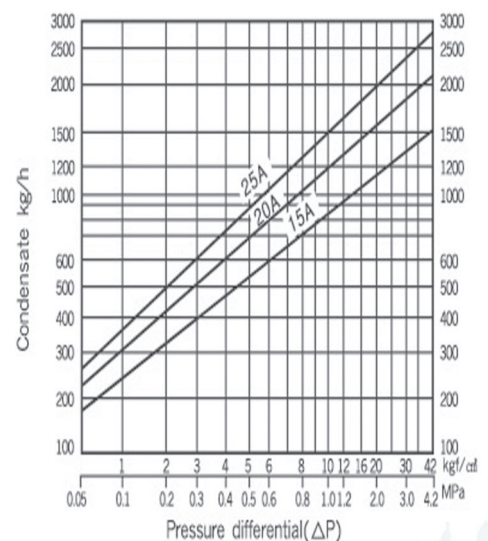

BST-1S | By Pass Type Steam Trap

- A built-in-pass valve allows to easily blow-off larger flow at initial operating and/or admissible flow into trap while opening the valve by handle.
- This type is useful to steam mains, especially suitable for laundry machines, and dyeing machines.

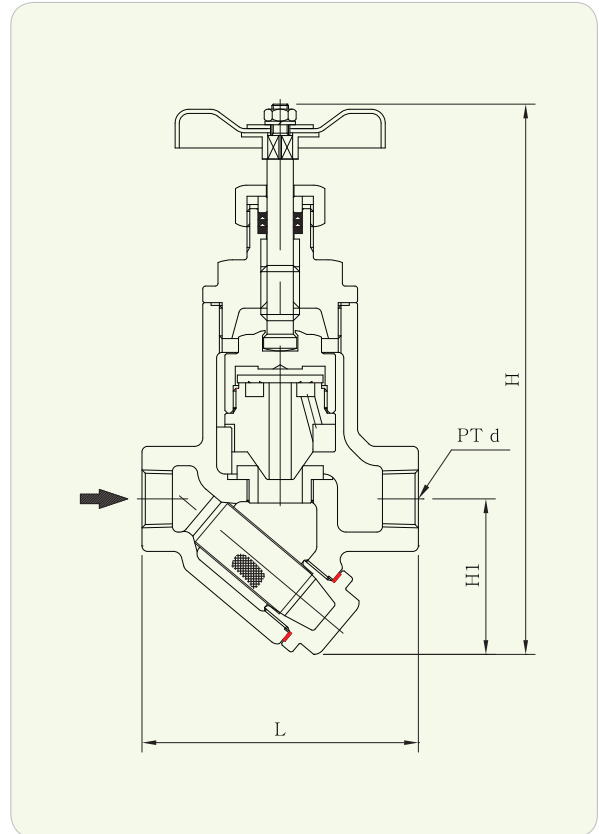

► Specifications

Working Pressure (kgf/cm ²)	Max. 16
	Min. 0.35
Working Temperature (°C)	220
Connection	PT Screwed
Materials	Body : Ductile Iron
	Trim : Stainless Steel

► Dimensions

Size	d	L	H1	H	Connection
15A	PT 1/2"	100	58	203	PT Screwed
20A	PT 3/4"	100	58	203	
25A	PT 1"	110	62	207	

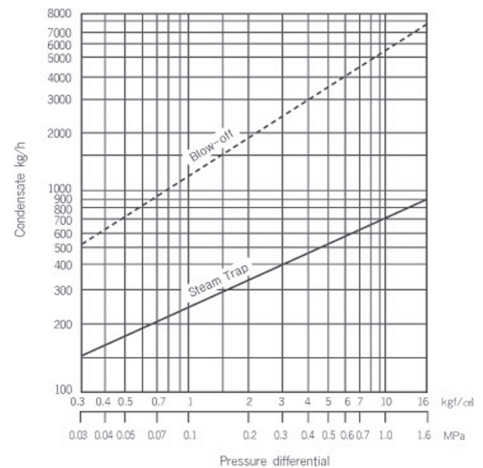

BKT-1S/1F | 버킷식 트랩(Bucket Type Steam Trap)

- It is an inverted type steam trap suitable for the heat exchangers, dryers and steam press, constructionally solving the air trouble by itself.
- All of the working parts are installed at the inside of the bonnet for easy disassembly and maintenance.

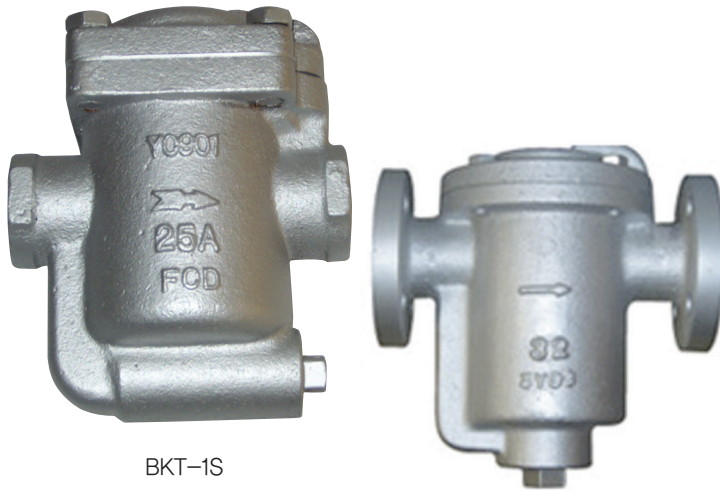

BKT-1S

BKT-1F

► Specifications

Working Pressure (kgf/cm ²)	Max. 8
	Min. 0.35
Working Temperature (°C)	220
Connection	BKT-1S : PT Screwed
	BKT-1F : JIS 10K Flanged
Materials	Body : Ductile Iron
	Trim : Stainless Steel

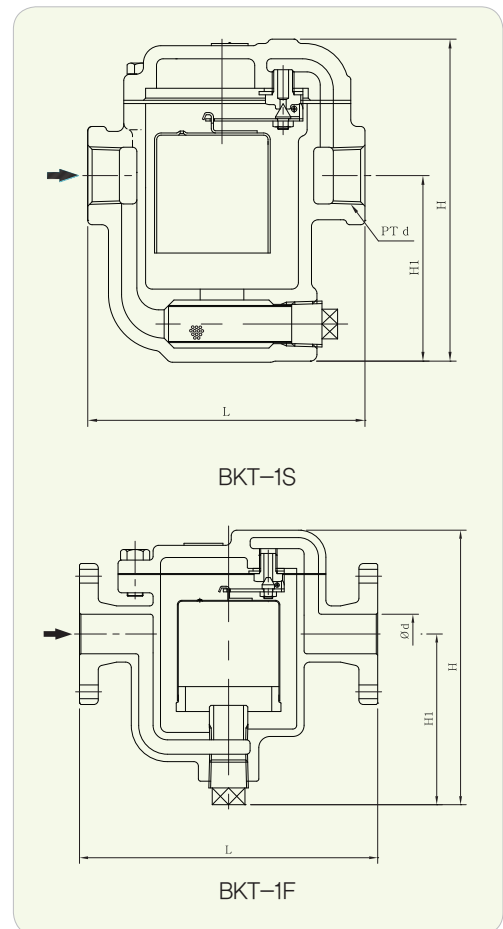

► Dimensions

Model	Size	d	L	H1	H	Connection
BKT-1S	15A	PT 1/2"	127	70	158	PT Screwed
	20A	PT 3/4"	127	70	158	
	25A	PT 1"	137	77	171	
	32A	PT 1 1/4"	190	190	280	
	40A	PT 1 1/2"	190	190	280	
	50A	PT 2"	240	200	300	
BKT-1F	32A	32	250	190	280	JIS 10K Flanged
	40A	40	250	190	280	
	50A	50	290	200	300	

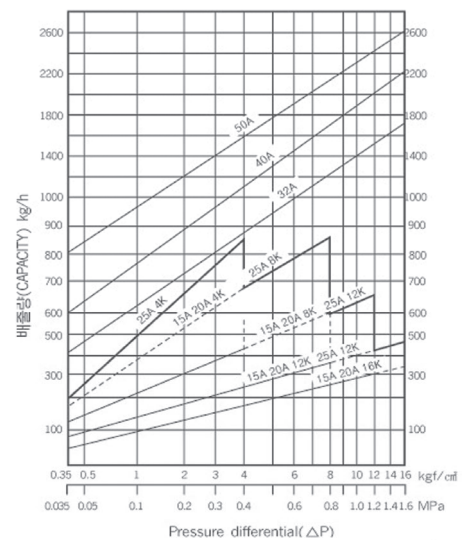

FLT-1S/1F/2F | Float Type Steam Trap

- For Application to larger capacity than thermodynamic trap such as heat exchanger, dryer, chemical plant, and various steam systems. Excellent durability of stainless steel disc, seat, and ball float. Inbuilt air vent assembly to eliminate air-binding.
- All parts are installed at the bonnet, and the integral bonnet would be helpful for easy maintenance.

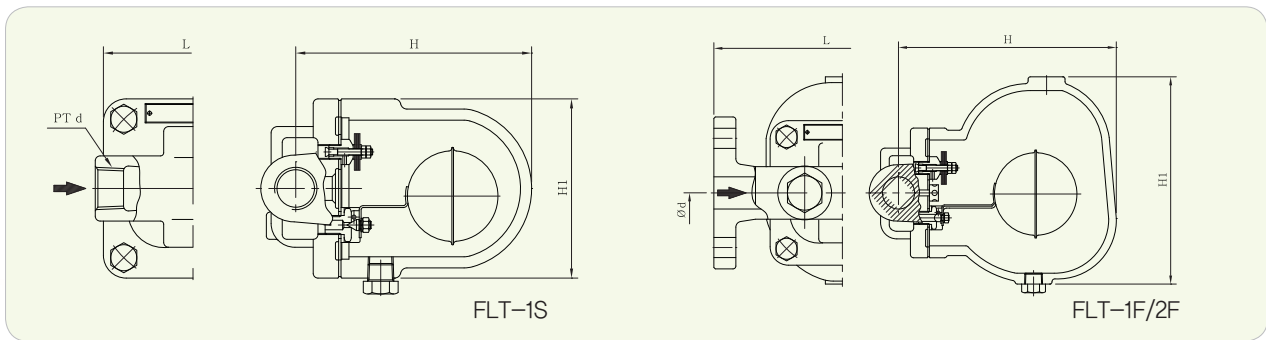
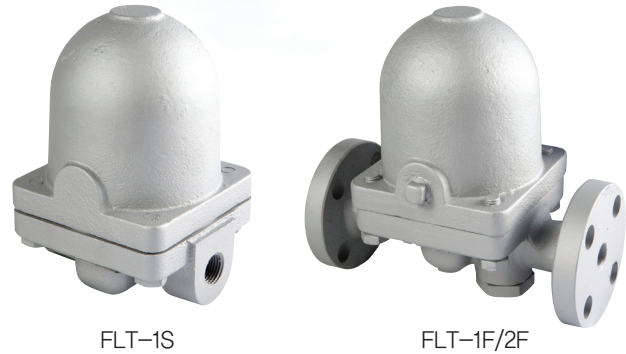

► Specifications

Working Pressure (kgf/cm ²)	Max. 4.5, 10, 14	Max.20
	Min. 0.35	Min. 0.35
Working Temperature (°C)	220	250
Connection	FLT-1S : PT Screwed	FLT-2F : JIS Flanged
	FLT-1F : JIS Flanged	
Materials	Body : Ductile Iron	Body : Cast Steel, Stainless Steel
	Trim : Stainless Steel	Trim : Stainless Steel

► Dimensions

Model	Size	d	L	H1	H	Connection
FLT-1S	15A	PT 1/2"	120	110	155	PT Screwed
	20A	PT 3/4"	120	110	155	
	25A	PT 1"	120	185	190	
	32A	PT 1 1/4"	270	240	295	
	40A	PT 1 1/2"	270	240	295	
	50A	PT 2"	300	260	310	
FLT-1F FLT-2F	15A	15	200	110	155	JIS 5K Flanged JIS 10K Flanged JIS 16K Flanged (FLT-1F) JIS 20K Flanged (FLT-2F)
	20A	20	200	110	155	
	25A	25	215	185	190	
	32A	32	320	240	295	
	40A	40	320	240	295	
	50A	50	360	260	310	

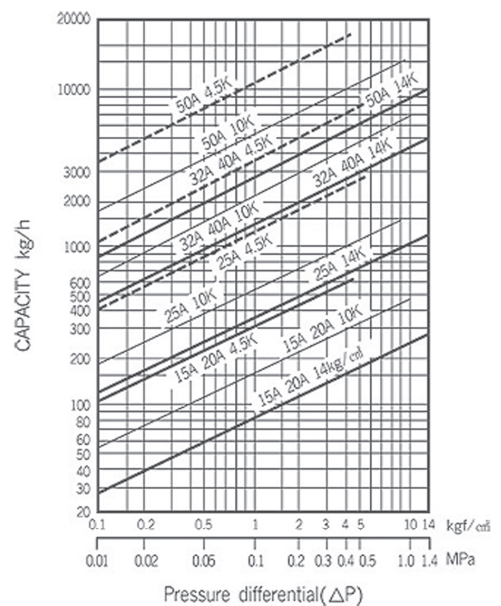

※ FLT-2F – ANSI and DIN Flange are available upon request

PST-2F | 피스톤식 스팀트랩(Piston Type Steam Trap)

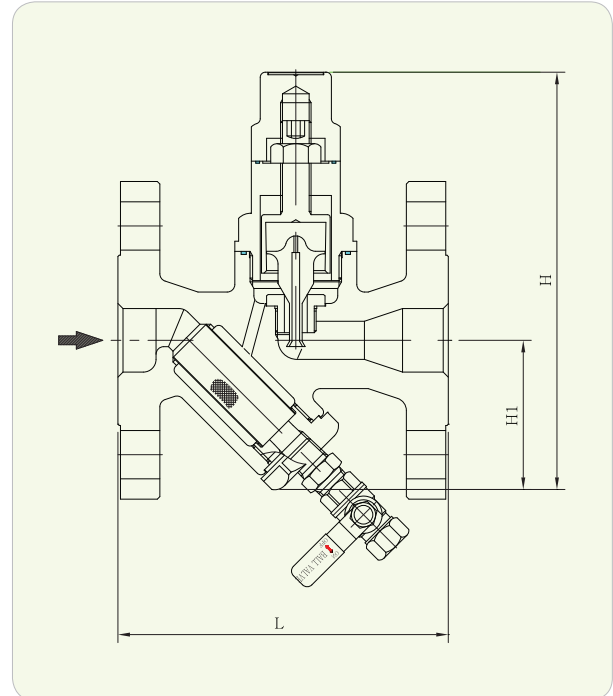

► Specifications

Working Pressure (kgf/cm ²)	Max. 20
	Min. 0.35
Working Temperature (°C)	220
Connection	JIS 16K, 20K Flanged
Materials	Body : Cast Steel, Stainless Steel
	Trim : Stainless Steel

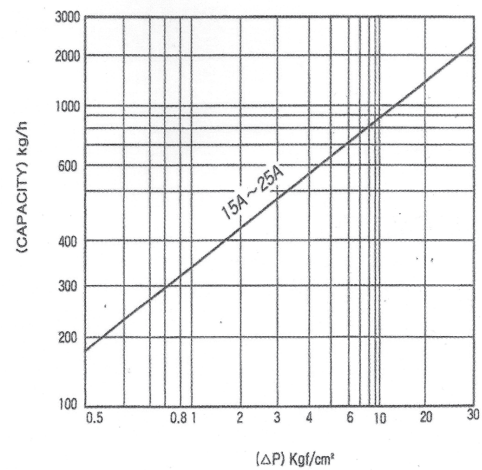

► Dimensions

Model	Size	d	L	H1	H	Connection
PST-2F	15A	15	126	60	165	JIS 16K, 20K Flanged
	20A	20	130	60	165	
	25A	25	130	60	165	

Reference Data | Accumulated Drain at steam pipe line

► When steam passes through at the beginning or accumulated Drain at unheated pipe line

A : when steam passes through at the beginning
B : Unheated pipe line

diameter(mm) pressure(kgf/cm ² g)		15	20	25	32	40	50	65	80	100	125	150	200	250	300
0.5 (110.7°C)	A	0.04	0.05	0.07	0.09	0.10	0.03	0.22	0.28	0.39	0.52	0.67	1.01	1.42	1.88
	B	0.08	0.10	0.13	0.16	0.18	0.23	0.29	0.33	0.42	0.52	0.61	0.80	0.99	1.17
1 (119.6°C)	A	0.04	0.05	0.07	0.10	0.11	0.15	0.25	0.30	0.43	0.58	0.74	1.11	1.57	2.07
	B	0.09	0.12	0.15	0.18	0.21	0.26	0.32	0.38	0.48	0.59	0.70	0.91	1.12	1.34
2 (132.9°C)	A	0.04	0.06	0.18	0.11	0.13	0.17	0.28	0.34	0.48	0.65	0.83	1.26	1.77	2.33
	B	0.11	0.14	0.18	0.22	0.25	0.31	0.39	0.46	0.58	0.71	0.84	1.10	1.35	1.61
3 (142.9°C)	A	0.05	0.06	0.09	0.12	0.14	0.18	0.30	0.37	0.52	0.71	0.90	1.37	1.93	1.61
	B	0.13	0.16	0.20	0.25	0.29	0.38	0.45	0.52	0.67	0.81	0.96	1.25	1.55	2.55
4 (151.1°C)	A	0.05	0.07	0.09	0.13	0.15	0.19	0.32	0.40	0.56	0.76	0.97	1.47	2.06	2.73
	B	0.14	0.18	0.22	0.28	0.32	0.39	0.50	0.58	0.74	0.90	1.07	1.40	1.72	2.05
5 (158.1°C)	A	0.05	0.07	0.10	0.13	0.16	0.20	0.34	0.42	0.59	0.80	1.02	1.55	2.18	2.88
	B	0.15	0.20	0.25	0.32	0.36	0.45	0.56	0.66	0.84	1.03	1.21	1.59	1.88	2.34
6 (164.2°C)	A	0.06	0.07	0.10	0.14	0.16	0.21	0.36	0.44	0.62	0.84	1.07	1.63	2.29	3.02
	B	0.16	0.21	0.26	0.33	0.37	0.46	0.58	0.68	0.87	1.06	1.26	1.65	2.03	2.43
7 (169.6°C)	A	0.06	0.07	0.11	0.14	0.17	0.22	0.37	0.46	0.65	0.87	1.11	1.69	2.38	3.14
	B	0.18	0.23	0.28	0.35	0.40	0.50	0.62	0.73	0.93	1.14	1.34	1.76	2.17	2.59
8 (174.5°C)	A	0.06	0.08	0.11	0.15	0.18	0.23	0.38	0.48	0.67	0.91	1.16	1.76	2.47	3.26
	B	0.19	0.24	0.30	0.37	0.42	0.53	0.66	0.77	0.99	1.21	1.28	1.87	2.31	2.76
9 (179.0°C)	A	0.06	0.08	0.12	0.15	0.18	0.24	0.40	0.49	0.70	0.94	1.20	1.82	2.56	3.39
	B	0.20	0.25	0.31	0.39	0.45	0.56	0.70	0.82	1.04	1.27	1.50	1.97	2.44	2.91
10 (183.2°C)	A	0.06	0.08	0.12	0.16	0.19	0.25	0.41	0.51	0.72	0.98	1.24	1.87	2.65	3.51
	B	0.21	0.27	0.33	0.41	0.47	0.58	0.73	0.86	1.09	1.34	1.58	2.07	2.56	3.05
15 (200.4°C)	A	0.07	0.09	0.13	0.18	0.21	0.28	0.46	0.57	0.18	1.09	1.39	2.12	2.98	3.94
	B	0.25	0.32	0.40	0.50	0.57	0.71	0.90	1.05	1.34	1.64	1.93	2.53	3.13	3.73
20 (213.9°C)	A	0.08	0.10	0.14	0.19	0.23	0.30	0.50	0.62	0.87	1.18	1.50	2.28	3.21	4.24
	B	0.29	0.26	0.46	0.57	0.65	0.81	1.02	1.19	1.53	4.87	2.21	2.89	3.57	4.26
30 (234.6°C)	A	0.00	0.12	0.174	0.23	0.27	0.35	0.59	0.73	1.03	1.39	1.77	2.69	3.78	5.00
	B	0.37	0.47	0.59	0.74	0.85	1.05	1.32	1.54	1.97	2.41	2.69	3.74	4.61	5.50

► Accumulated Drain when it is heated at pipe line

Temperature	Pipe size (mm)	15	20	25	32	40	50	65	80	100	125	150	200	250	300
100	Warm athickness mm	15	15	15	15	15	15	15	20	20	20	20	20	20	20
	Accumulated Drain kg/min	0.05	0.06	0.07	0.08	0.08	0.10	0.11	0.12	0.14	0.17	0.19	0.23	0.27	0.31
150	Warm athickness mm	15	15	20	20	20	20	25	25	25	25	25	25	30	30
	Accumulated Drain kg/min	0.09	0.10	0.11	0.12	0.13	0.14	0.17	0.18	0.20	0.23	0.26	0.32	0.37	0.42
200	Warm athickness mm	20	20	20	25	25	25	25	25	30	30	30	35	35	35
	Accumulated Drain kg/min	0.12	0.14	0.15	0.15	0.17	0.19	0.22	0.24	0.28	0.32	0.36	0.43	0.50	0.58
250	Warm athickness mm	20	25	25	25	25	30	30	30	35	35	35	40	40	40
	Accumulated Drain kg/min	0.17	0.19	0.20	0.22	0.23	0.26	0.30	0.33	0.38	0.43	0.49	0.58	0.68	0.78
300	Warm athickness mm	25	25	25	30	30	30	35	35	40	40	40	45	45	45
	Accumulated Drain kg/min	0.22	0.25	0.28	0.30	0.33	0.37	0.42	0.46	0.53	0.60	0.68	0.80	0.94	1.08

Reference Data | Table of saturated vapour

Absolute pressure for steam (a b c)		Temperature of steam		Volume of water tkg before evaporation	Volume of steam tkg	Weight of steam 1m2	Specific enthalpy of steam tkg			Absolute pressure for steam (a b c)		Temperature of steam		Volume of water tkg before evaporation	Volume of steam tkg	Weight of steam 1m2	Specific enthalpy of steam tkg		
							Heat	Latent heat	Total heat								Heat	Latent heat	Total heat
kgf /cm ²	lb/ In ²	°C	°F	ℓ	m ³	kg	h	L	H=h+L	kgf /cm ²	lb/ In ²	°C	°F	ℓ	m ³	kg	h	L	H=h+L
0.02	0.28	17.2	629	1.0012	68.26	0.147	17.2	587.8	605.0	13.5	192.0	192.4	378.3	1.1451	0.1485	6.734	195.5	469.9	665.4
0.04	0.57	28.6	83.5	1.0039	35.45	0.0288	28.7	581.3	610.0	14.0	199.1	194.1	381.4	1.1476	0.1436	6.974	197.3	468.4	665.7
0.06	0.85	35.8	96.4	1.0063	24.18	0.0414	35.8	577.3	613.1	14.5	206.2	195.8	384.4	1.1500	0.1386	7.214	199.0	466.9	665.9
0.08	1.14	41.2	106.2	1.0083	18.44	0.0542	41.2	574.2	615.4	15.0	213.3	197.4	387.3	1.1524	0.1342	7.454	200.7	465.5	666.2
0.10	1.42	45.5	113.9	1.0101	14.95	0.0669	45.4	571.8	617.2	16.0	227.4	200.4	392.7	1.1572	0.1260	7.934	204.1	462.6	666.7
0.15	2.14	53.6	128.5	1.0136	10.21	0.0980	53.5	567.1	620.6	17.0	241.7	203.4	398.1	1.1618	0.1189	8.414	207.2	459.9	667.1
0.20	2.84	59.7	139.5	1.0170	7.791	0.1284	59.6	563.5	623.1	18.0	256.0	206.2	403.2	1.1663	0.1124	8.894	210.2	457.2	667.4
0.25	3.56	64.6	148.3	1.0197	6.319	0.1583	64.5	560.8	625.2	19.0	270.2	208.8	407.8	1.1706	0.1067	9.375	213.1	454.1	667.7
0.30	4.27	68.7	155.7	1.0221	5.326	0.1878	68.7	558.2	626.9	20.0	284.4	211.4	412.5	1.1749	0.1015	9.857	215.9	452.1	668.0
0.35	4.98	72.3	162.1	1.0242	4.409	0.2170	72.2	556.1	628.3	21.0	298.6	213.9	417.0	1.1791	0.0967	10.34	218.6	450.6	668.2
0.40	5.69	75.5	167.7	1.0362	4.067	0.2459	75.4	554.2	629.6	22.0	312.8	216.2	421.2	1.1833	0.0924	10.85	221.2	447.2	668.4
0.45	6.40	78.3	172.9	1.0280	3.642	0.2746	78.3	552.5	630.8	23.0	327.1	218.5	425.3	1.1873	0.0885	11.31	223.8	448.8	668.6
0.50	7.11	80.9	177.6	1.0296	3.300	0.3030	80.3	550.9	631.8	24.0	341.3	220.8	429.4	1.1913	0.0848	11.79	226.2	442.6	668.8
0.60	8.53	85.5	185.9	1.0329	2.782	0.3594	85.5	548.1	633.6	25.0	355.5	222.9	433.2	1.1953	0.0815	12.28	228.6	440.3	668.9
0.70	9.95	89.5	193.1	1.0357	2.408	0.4152	89.5	545.7	635.2	26.0	369.7	225.0	437.0	1.1991	0.0784	12.76	230.9	438.1	669.0
0.80	11.4	93.0	199.4	1.0383	2.125	0.4705	93.0	543.5	636.5	27.0	383.9	227.0	440.6	1.203	0.0755	13.25	233.2	435.9	669.1
0.90	12.8	96.2	205.2	1.0407	1.8904	0.5253	96.2	541.5	637.5	28.0	398.2	229.0	442.2	1.207	0.0728	13.74	235.4	433.8	669.2
1.00	14.2	99.1	210.4	1.0430	1.755	0.5797	99.2	539.6	638.8	29.0	412.4	230.9	447.5	1.210	0.0703	14.23	237.5	431.7	669.2
1.20	17.1	104.3	219.7	1.0471	1.454	0.6875	104.4	536.3	640.7	30.0	426.6	232.8	451.0	1.214	0.0679	14.72	239.6	429.7	669.3
1.40	19.9	108.7	227.7	1.0580	1.259	0.7942	108.9	535.5	642.4	32.0	455.0	236.4	457.5	1.221	0.0637	15.70	243.7	425.6	669.3
1.60	22.8	112.7	234.9	1.0542	1.111	0.8999	112.9	530.8	643.7	34.0	483.5	239.8	463.6	1.229	0.0599	16.69	247.6	421.7	669.3
1.80	25.6	116.3	241.3	1.0573	0.9952	1.005	116.6	528.4	645.0	36.0	511.9	243.0	469.4	1.236	0.0565	17.69	251.3	417.9	669.2
2.00	28.4	119.6	247.3	1.0603	0.9018	1.109	119.9	526.3	646.2	38.0	540.4	246.2	475.2	1.243	0.0535	18.69	254.9	414.2	669.1
2.50	35.6	126.8	260.2	1.0669	0.7317	1.367	127.2	521.4	648.6	40.0	566.8	249.2	480.6	1.249	0.0508	19.70	258.4	410.5	669.9
3.00	42.7	132.9	271.2	1.0726	0.6168	1.621	133.4	517.2	650.6	42.0	597.2	252.1	485.8	1.256	0.0483	20.72	261.7	407.0	669.7
3.50	49.8	138.2	280.8	1.0782	0.5337	1.874	138.8	513.4	652.2	44.0	625.7	254.9	490.8	1.263	0.0460	21.74	265.0	403.5	668.5
4.00	56.9	142.9	289.2	1.0831	0.4708	2.124	143.7	510.0	653.7	46.0	654.1	257.6	495.7	1.269	0.0439	22.77	268.2	400.0	668.2
4.50	64.0	147.2	297.0	1.0877	0.4214	2.373	148.1	506.8	654.9	48.0	628.6	260.2	500.4	1.276	0.0420	23.80	271.3	396.6	667.9
5.00	71.1	151.1	304.0	1.0920	0.3816	2.620	152.1	503.9	656.0	50.0	711.0	262.7	504.9	1.283	0.0402	24.85	274.3	393.3	667.6
5.50	78.2	154.7	310.5	1.0961	0.3489	2.877	155.8	501.2	657.0	55.0	782.1	268.7	515.7	1.299	0.0364	27.49	278.5	385.1	666.6
6.00	85.3	158.1	316.6	1.1000	0.3213	3.112	159.3	498.6	657.9	60.0	853.2	274.3	525.7	1.315	0.0331	30.18	288.3	377.2	665.5
6.50	92.4	161.2	322.2	1.1037	0.2980	3.356	162.6	496.1	658.7	65.0	924.3	279.5	535.1	1.331	0.0304	32.93	294.8	369.4	664.2
7.00	99.5	164.2	327.6	1.1072	0.2778	3.660	165.7	493.8	659.5	70.0	995.4	284.5	544.1	1.347	0.0280	35.75	301.0	361.8	662.8
7.50	106.7	167.0	332.6	1.1111	0.2602	3.843	168.6	491.6	660.2	75.0	1066.5	289.2	552.6	1.363	0.0259	38.62	307.0	354.3	661.3
8.00	113.8	169.6	337.3	1.1140	0.2448	4.086	171.3	488.5	660.8	80.0	1137.6	293.6	560.5	1.379	0.0241	41.56	312.8	346.9	659.7
8.15	120.9	172.1	341.8	1.1172	0.2311	4.328	174.0	487.4	661.4	85.0	1208.7	297.9	568.2	1.395	0.0224	44.58	318.4	339.6	658.0
9.00	128.0	174.5	346.1	1.1203	0.2188	4.570	176.5	485.4	661.9	90.0	1279.5	301.9	575.4	1.421	0.0210	47.67	323.8	332.4	655.2
9.50	135.1	176.8	350.2	1.2333	0.2079	4.811	178.9	483.5	662.4	95.0	1350.9	305.8	582.4	1.429	0.0197	50.85	329.1	325.2	654.3
10.00	142.2	179.0	354.2	1.1262	0.1979	5.052	181.3	481.6	662.9	100	1422.0	309.5	589.1	1.446	0.0185	54.12	334.3	318.0	642.3
10.50	149.3	181.2	358.2	1.1291	0.1890	5.283	183.5	479.8	663.3	120	1706.4	323.1	613.6	1.518	0.0147	68.22	354.0	289.4	643.4
11.00	156.4	183.2	357.8	1.1319	0.1807	5.533	185.6	478.1	663.7	140	1990.8	335.1	633.2	1.599	0.0118	84.52	372.8	260.0	632.8
11.50	163.5	185.2	365.4	1.1346	0.1732	5.774	187.7	476.4	664.1	160	2275.2	345.8	654.4	1.693	0.0096	104.0	391.3	228.4	619.7
12.00	170.6	187.1	368.8	1.1372	0.1663	6.014	189.8	474.7	664.5	180	2559.6	355.4	671.7	1.814	0.0078	128.3	410.8	129.9	603.7
12.50	177.8	188.9	372.0	1.1400	0.1599	6.254	191.7	473.1	664.8	200	2844.0	346.1	687.4	1.990	0.0062	161.6	431.6	151.2	582.8
13.00	184.9	190.7	375.3	1.1425	0.1540	4.494	193.6	471.5	665.1	225.56	3208.7	374.15	705.47	3.170	0.0032	315.5	503.3	0	503.3